

ART. 00450, 00451, 00452, 00453 Scatole da pavimento con coperchio reversibile

Art. 00452

Art. 00453

Art. 00450

Art. 00451

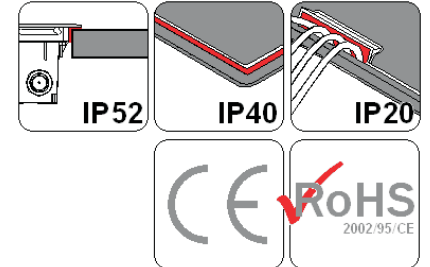
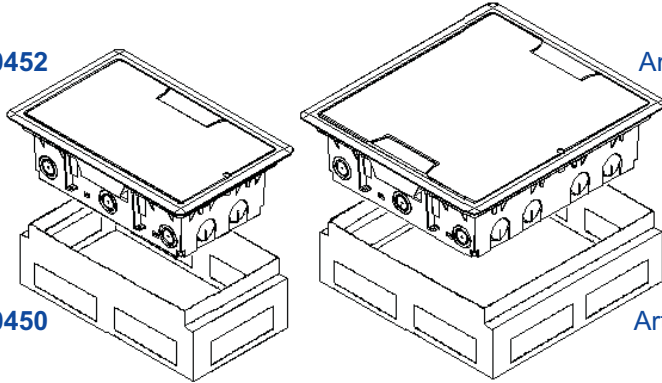

Preparazione del pavimento flottante
Predisposition for false floor

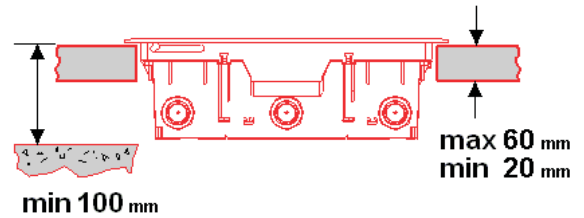
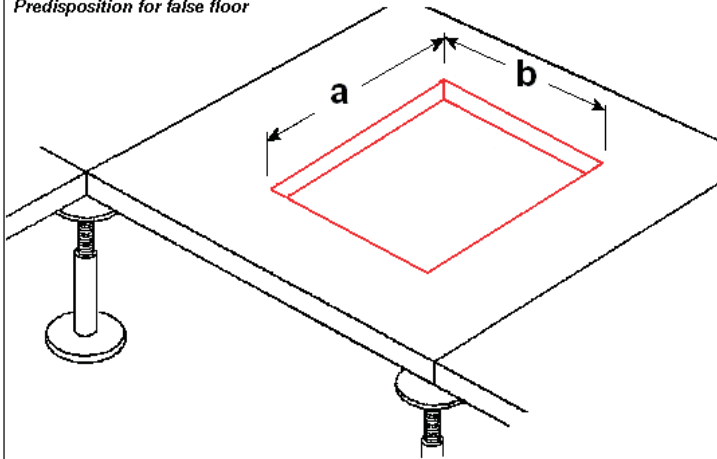

	a mm	b mm
Art. 00452	190	307
Art. 00453	342	307

Preparazione cassaforma per pavimento gettato
Predisposition box for concrete floor

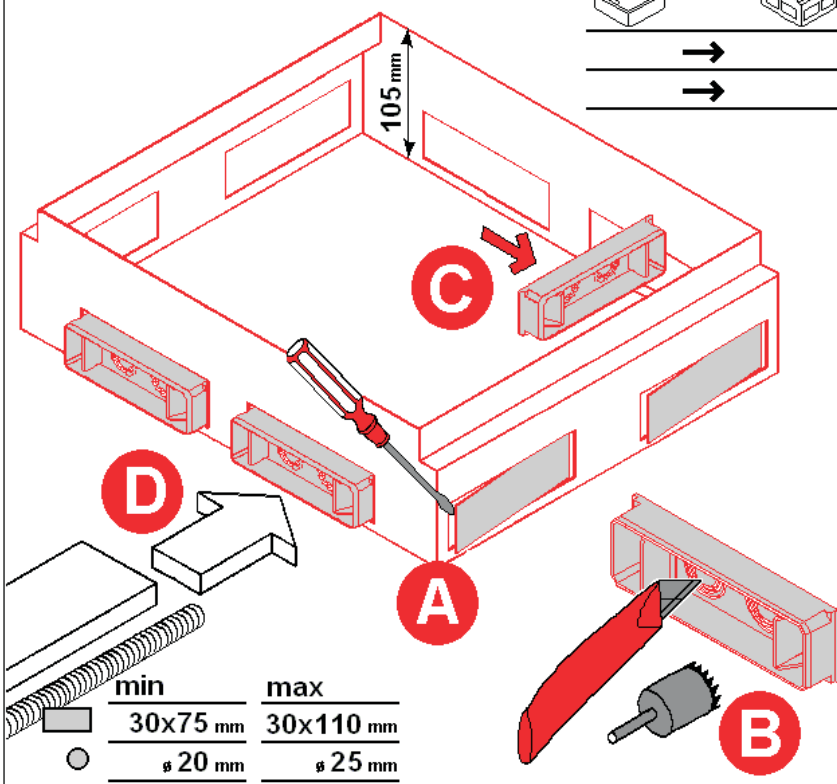
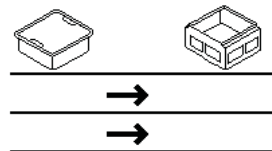

Collegare a terra la cassaforma
Earth the box

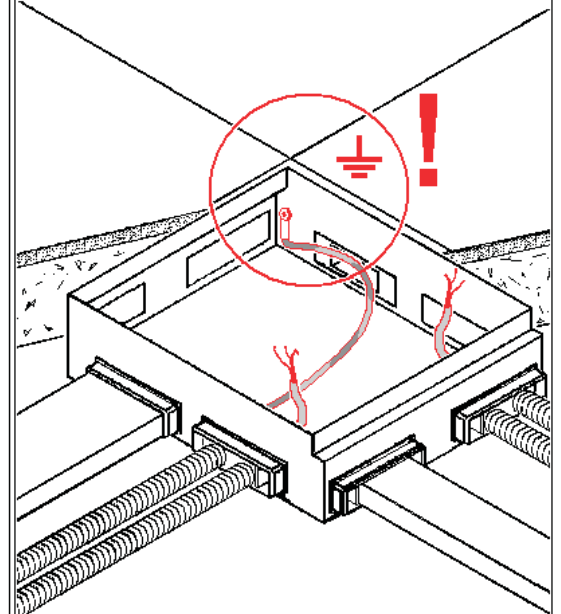

Smontare il coperchio prima di iniziare il cablaggio

Dismount the cover before cabling operation

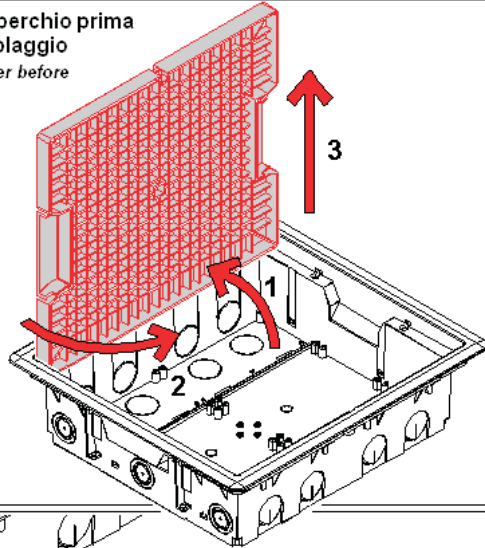

Preparare i fianchi della scatola per inserire i cavi

Prepare side openings for cables insertion

N.B. per una corretta installazione usare pressacavi o pressaguaina

N.B. For proper installation use cableglands or joint for box-sheath

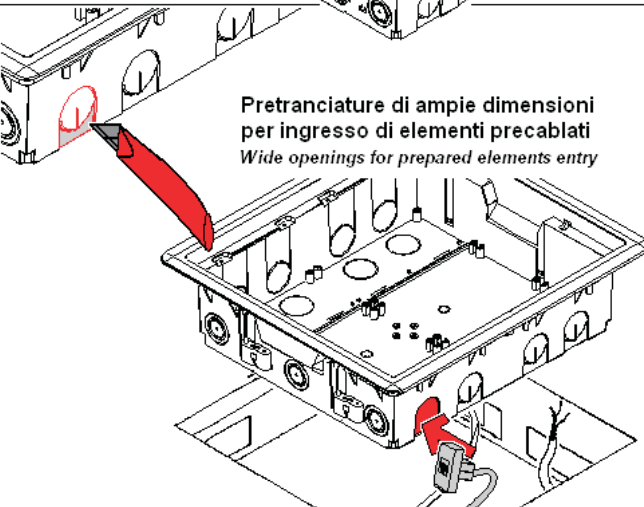
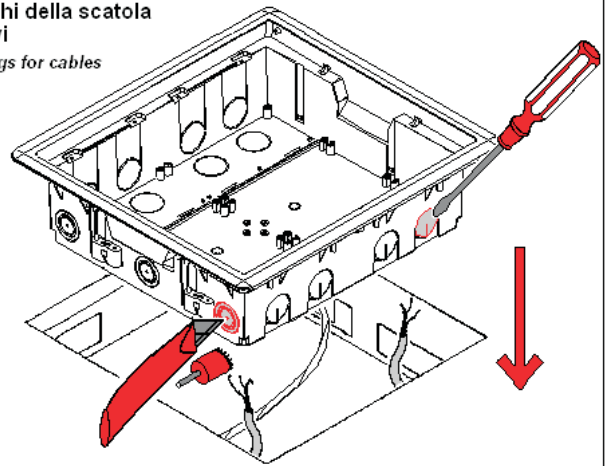
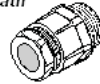

Pretranciature di ampie dimensioni per ingresso di elementi precablati
Wide openings for prepared elements entry

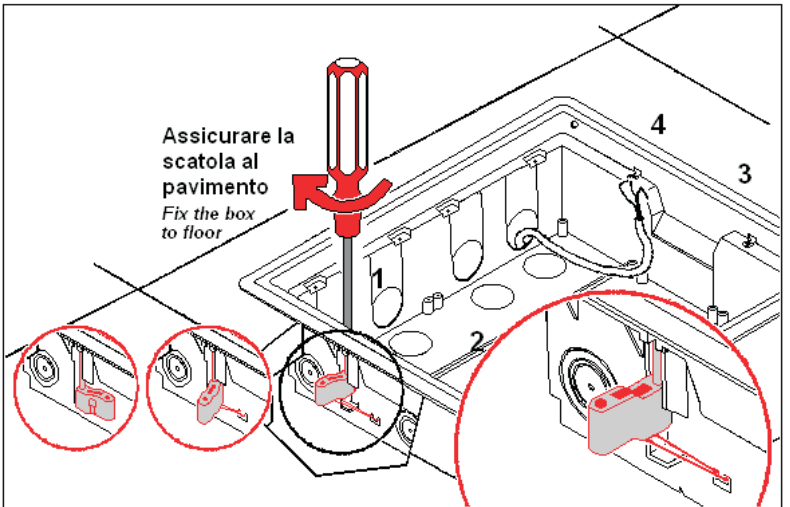

Assicurare la scatola al pavimento
Fix the box to floor

SUPPORTO UNIVERSALE PER TELAI A 3-4 MODULI

UNIVERSAL SUPPORT FRAME FOR 3-4 MODULES

Art. 00456

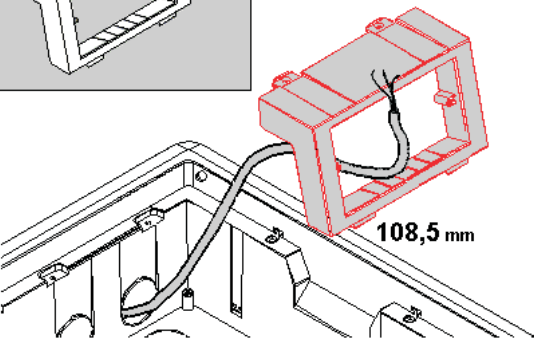
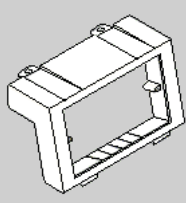

108,5 mm

Cablare gli apparecchi ed unirli al telaio

Avvitare il telaio al supporto
Fix appliances to the frame
Screw the frame to the support

Art. 38004 o 38004-F per serie Modo/Mix

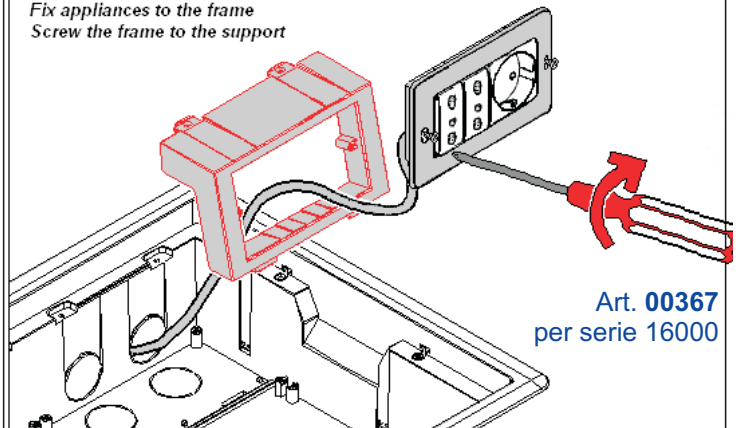

Art. 00367 per serie 16000

Applicare la placca di finitura
Apply the finishing plate

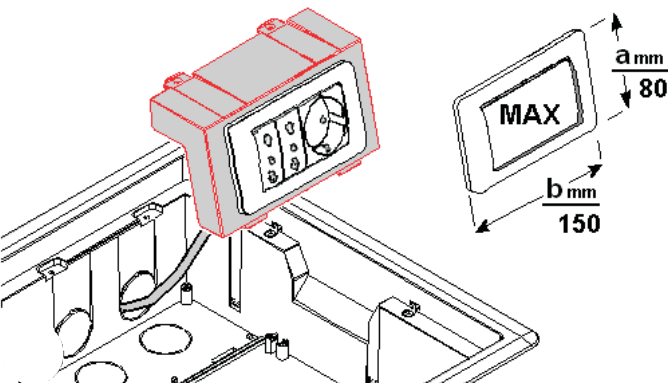

a mm

80

b mm

150

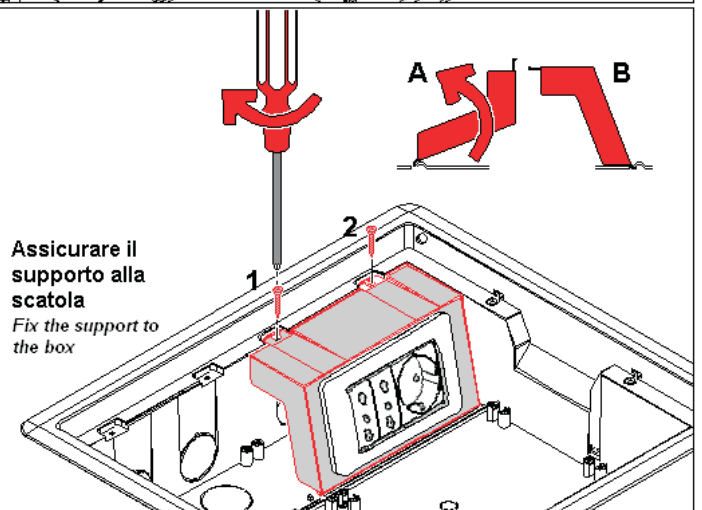

Assicurare il supporto alla scatola
Fix the support to the box

SUPPORTO AUTOPORTANTE PER MODO / MIX

SELF SUPPORT FOR MODO/MIX SERIES

Art. 00455

Inserire gli apparecchi dall'interno
Insert appliances from back

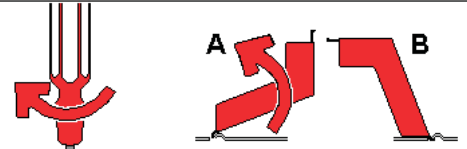
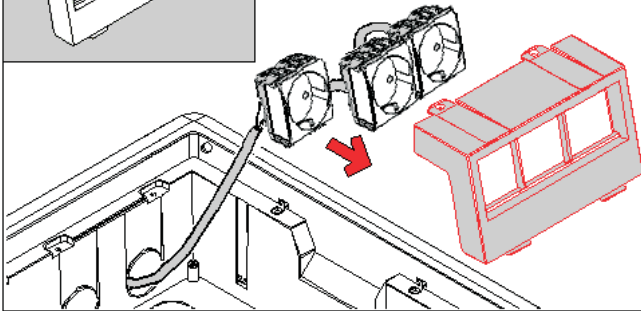
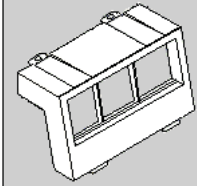

Assicurare il supporto alla scatola
Fix the support to the box

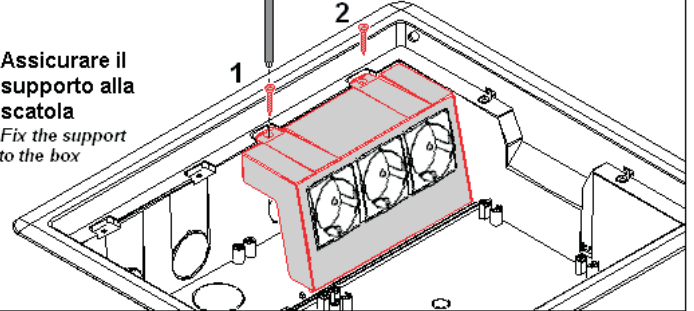

SUPPORTO PER INTERRUPTORE AUTOMATICO

SUPPORT FRAME FOR MODULAR SWITCHES

Art. 00457

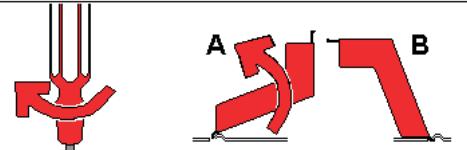
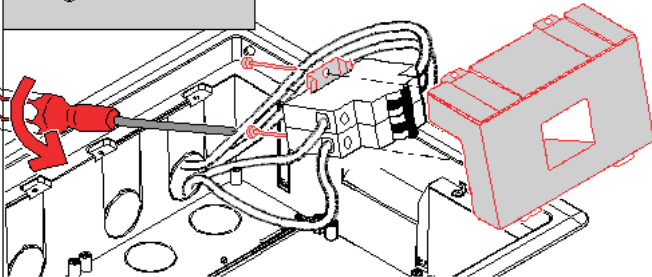
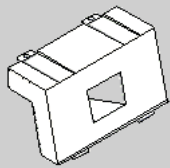

Assicurare il supporto alla scatola
Fix the support to the box

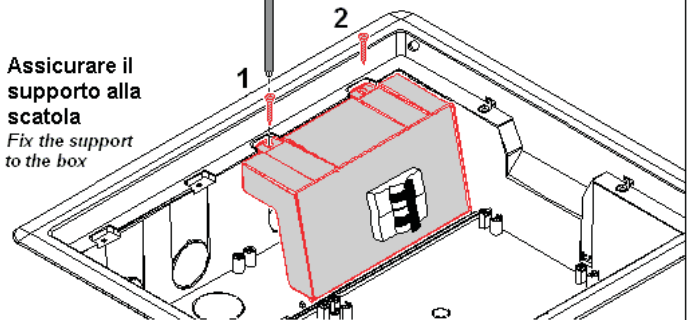

Montare i fermacavi interni dopo avere assicurato i supporti
Fix the inner cableclamps after supports mounting

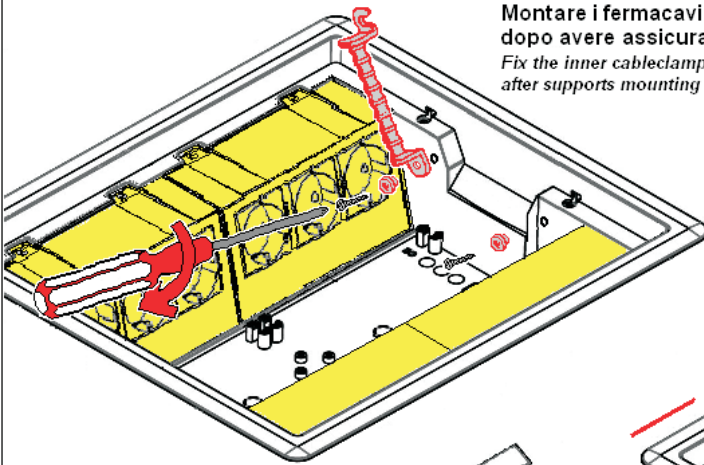

Lato della cerniera del coperchio
Cover hinge side

Lato Destro
Right side

Lato Sinistro
Left side

